

股票代码 STOCK CODE: 838363

SWITEK[®]
思为客

Guang Dong Switek Technology Co., Ltd.

Nanwei Industrial District, Chashan Town,
Dongguan City, Guangdong Province, China
Sales@switek.biz
www.switekautomation.com

广东思为客科技股份有限公司

地址: 广东省东莞市茶山镇塘边南围工业区5号
邮编: 523378
电话: +86 769 8239 8229
传真: +86 769 8185 9017



SW7 Series 3 Axis Servo Robot
技术参数 | SPECIFICATION
IMM 3500 - 40000kN

技术参数 | Specification

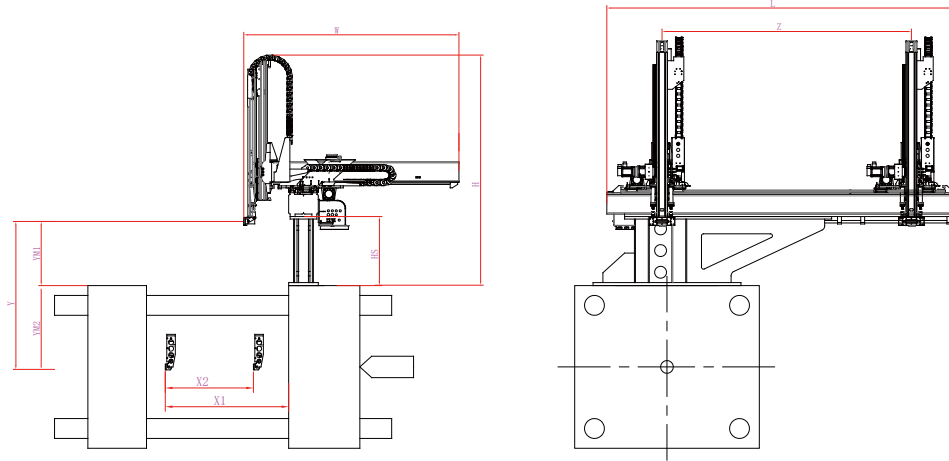

核心配件 | Key Components

品名 Name	品牌 Brand
伺服马达 Servo Motor	松下 Panasonic
减速机 Reducer	新宝 Shimpo
滑轨 Sliding Rail	THK
接头 Plug	费斯托 Festo
气缸 Air Cylinder	亚德客 AirTAC
皮带 Belt	意拉泰 Elatech
继电器 Relay	欧姆龙 OMRON
拖链电缆 Flexible Cable	易格斯 IGUS
电磁阀 Solenoid Valve	亚德客 AirTAC
真空发生器 Vacuum Generator	亚德客 AirTAC
轴承 Bearing	日本精工 NSK
控制系统 Control System	思为客 SWITEK

机型 Model	主臂最远位置	主臂引拔行程	手臂上下行程	待机高度	安装面下行高度	机器宽度	机器长度	横行行程	机器高度	底座高度	负载	适应注塑机	马达功率 Motor Power			吸盘气路	夹(抱)具气路	干循环周期	最大线速度(m/s) Max Line Speed			功耗 (KVA)	输入电压	工作气压 (kgf/cm2)	最大空气消耗量 (NL/Cycle)
	X1	X2	Y	YM1	YM2	W	L	Z	H	HS	Payload	I,M,M	X	Y	Z	Vacuum	Chuck Pipe	Dry Cycle Time	X	Y	Z	Power	Power Input	Working Pressure	Air Consumption
SW7312DS	1020	730	1200	460	740	1660	2600	1700	2110	700	5kg	350-650T	750	750	750	2	2	8s	2	2	2	3.9	AC220V/1Phs	5~7	3.5
SW7515DS	1485	1020	1500	650	850	2180	3520	2530	2330	700	15kg	500-1000T	2000	2000	2000	2	2	12s	2	3	2	9	AC220V/3Phs	5~7	4.5
SW7518DS	1785	1320	1800	650	1150	2480	4160	3170	2510	700	15kg	500~1300T	2000	2000	2000	2	2	12s	2	3	2	9	AC220V/3Phs	5~7	4.5
SW7522DS	2145	1680	2200	650	1550	2840	4160	3170	2690	700	15kg	500~1800T	2000	2000	2000	2	2	12s	2	3	2	11.4	AC220V/3Phs	5~7	5
SW7722DS	2250	1720	2200	680	1520	3000	5050	4000	2980	850	50kg	800~2800T	2000	3000	3000	2	2	16s	2	3	2	12.8	AC220V/3Phs	5~7	8
SW7725DS	2250	1720	2500	730	1770	3000	5050	4000	3120	900	50kg	1000~3000T	2000	3000	3000	2	2	16s	2	3	2	12.8	AC220V/3Phs	5~7	8
SW7730DS	2250	1720	3000	780	2220	3000	5050	4000	3260	950	75 kg	1400~4000T	2000	5000	3000	2	2	16s	2	3	2	14.6	AC220V/3Phs	5~7	9



多语言支持 | Multi-Language



- 8.4 “触屏LCD, 人机界面友好”
8.4” Touch Screen LCD, Operator Friendly HMI
- DSP+FPGA控制: 系统响应速度快, 动作控制精度高, 定位精度0.01mm
DSP+FPGA Control, Fast System Response With a Repeatability up to 0.01mm
- 新版示教模式: 全新的指令模式, 更加丰富完善的示教指令
New Teaching Mode with Richer Teaching Commands
- 堆叠功能: 预置多种堆放方式, 简化不同产品的堆放示教
With a Variety of Built-in Stacking Setting to Simplify the Teaching Process
- 丰富的保护功能: 自动检测机器运行状态, 及时显示故障报警及原因
Safe: Machine Running Status Auto-detection, Just-in-time Alarm and Error Code Report
- 可扩展IO: 可外接多个IO板, 满足机器复杂的PLC外部编辑器
Scalable IO: It's Allowed to Connect more IO Board for Complex PLC Programming
- 支持CAN,RS485等拓展外部伺服控制
External Servo Control such as CAN, RS485 etc. Supported
- U盘升级: 可随时更新最新系统, 持续获得稳定支持
To Upgrade the System with a USB Key for an Up to Date Support
- 支持串联六关节、SCARA、DELTA等不同类型机器人结构算法
A Series Connection to Different Robots such as Articulated Robot, Scara, Delta etc. Supported
- 支持注册功能
Registration Supported
- 可定制的安全模块, 可根据自身需求预置安全检查策略
It's Allowed to Custom Made the Safety Mode for Special Security Checking Strategy
- 可定制的曲线路径规划, 厂家可根据产品特点预置不同的轨迹生产方案
Robot Arm Moving Trail Pre-setting Function for Different Production Sequences
- 可通过U盘在不同的机器间导入导出机器参数、模号程序等, 使调节更高效
Input/Output Machine Data or Program In-between Machines for faster Startup



Guang Dong Switek Technology Co., Ltd.

Nanwei Industrial District, Chashan Town,
Dongguan City, Guangdong Province, China
Sales@switek.biz
www.switekautomation.com

广东思为客科技股份有限公司

地址：广东省东莞市茶山镇塘边南围工业区5号
邮编：523378
电话：+86 769 8239 8229
传真：+86 769 8185 9017



成立于2006年，广东思为客科技股份有限公司是一家专注于机械手、模内贴及相关注塑后端自动化应用系统开发的高新技术企业。自成立以来，公司坚持“用户第一、诚信为本”的企业核心价值观，狠抓产品质量，不断完善产品的售后服务，整体通过ISO9001:2015质量体系认证并获欧盟CE认证，产品远销40多个国家和地区。

自成立以来，思为客积极同各大注塑机及模具厂商展开技术交流，在模内贴、管件接头注塑自动化、餐具包装、盖类装箱自动化、装配自动化等领域展开深入合作，为全球用户提供高效的整体注塑自动化解决方案。

Founded in 2006, SWITEK is a manufacturing company of robots for injection molding automation. Strictly follow up the ISO9001:2015 regulation, SWITEK robots are CE Certified and exported to more than 40 countries and districts.

From the very beginning, SWITEK always working closely with the injection molding machine manufacturers and the mold maker to provide clients around the world an efficient injection molding automation solution.